



Take advantage of the space around your loading doors with

Over-Dock Pallet Storage Racks



Great for storing:

- *Empty pallets*
- *Empty cartons*
- *Packing materials*

Your Solution to Empty Pallet Storage Problems

Loading docks cluttered with loose pallets and cartons are a common problem for many facilities. It's not just an aesthetic problem; it's one of safety and operational efficiency.

Two decades ago, Steel King recognized the problem and pioneered the solution: Over-Dock Pallet Storage Racks.

Steel King's standard SK2000 or SK3000 can be designed and configured to fit around your loading dock doors – letting you take advantage of otherwise wasted space.

STEEL KING[®]

Use your loading area efficiently

Steel King has designed two unique over-dock racking products to help you efficiently use space and reduce the chance of lift-truck impact. Two designs are offered – a single-leg, wall-tied system and a ceiling-supported system with no lower legs.

Single-Leg, Wall-Tied

The single-leg, wall-tied design features an upright frame with a special offset leg and a single, back column support up to a height that will clear the door. Single-leg, wall-tied systems are best suited for buildings with poured concrete walls or exposed-column buildings. The heavy-duty wall ties used to stabilize the frame vary in length; beam lengths also vary to clear the door. Single-leg, wall-tied racking systems should be used primarily for empty pallets or light loads.

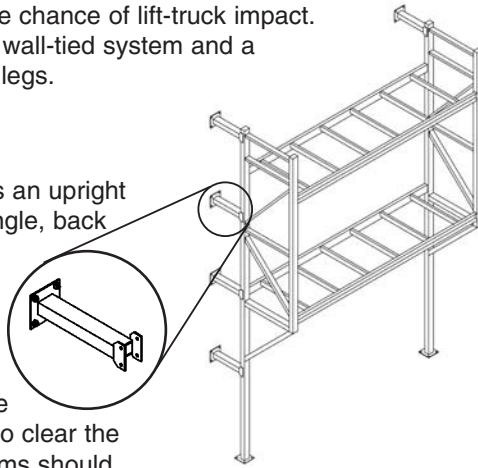

One advantage of this system is that the front post, where most potential damage occurs, is removed. The single-leg, wall-tied design is anchored to the floor with four bolts. The rack system needs to be secured with heavy-duty wall ties. Each wall tie is bolted to the rack column and anchored to the concrete wall or exposed building column.

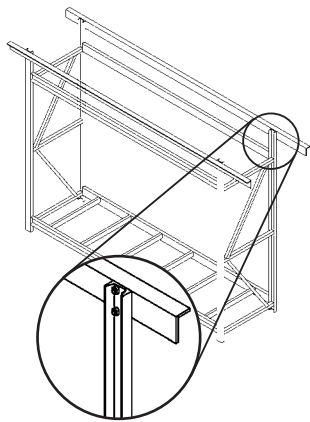

Ceiling-Supported System

The ceiling supported over-dock racking system must be designed in conjunction with the building architect who must verify the adequacy of the building to support the additional weight of the racking and the pallets.

Since the structural cross bars of the rack frames of the suspended system are field welded or bolted to the roof trusses or girders, the system is suitable for buildings with any wall type. The suspended over-dock storage rack does not have lower legs; there is no interference with forklift or other traffic.



Rack Construction

- Structural channel load beams with bolted connections
- Two bolt-in pallet supports under each pallet position
- Safety netting or bolt-in steel retaining straps used at the back of each rack bay to positively retain pallets

Optional Accessories

- Post protection with the Steel Guard system (recommended for single leg racks)
- Column Core adds five times the strength to columns
- Guard Dawg safety rail system

Your local Steel King representative, along with our engineering department, would be pleased to develop a design specifically for your facility.



STEEL KING

2700 Chamber St., Stevens Point, WI 54481
(715) 341-3120 • (800) 826-0203
Fax: (715) 341-8792

info@steelking.com • www.steelking.com

Your Steel King Distributor:

