

# Enclosed Track Workstation Bridge Cranes

- Freestanding
- Ceiling-Mounted
- Monorails
- Alu-Track® Systems



# Bridge Crane Selector Guide



Workstation Crane Type	Freestanding Bridge Crane	Ceiling-Mounted Bridge Crane	Monorails	Alu-Track® Bridge & Runways (incl. Monorails)
Capacities	250 to 4000 lbs		250 to 4000 lbs	250 to 3000 lbs
Bridge Lengths (overall)	Standard up to 34' Available to 40'		n/a	up to 30'
Runway Support Centers	up to 40'		up to 40'	up to 29'
Height (floor to trolley clevis)	10', 12', or 14' are standard	Varies, but lower heights mean easier bridge motion		See Freestanding, Ceiling-Mounted & Monorails left
Runway Lengths (w/o splices)	53' (w/o splicing) or Unlimited (w/ splicing)			30'
Coverage	Large rectangle or square-shaped areas		Any fixed path, including curves	See left
Existing Structure Needed	6" reinforced concrete floor	Adequate roof support/trusses	Adequate roof support/trusses or 6" reinforced concrete floor	See left
Can Be Motorized?	Yes, both hoist & bridge		Yes	No
Key Options Available	Mixed Capacity; Vacuum Hose Trolleys; Bridge Buffers; Intermediate Stops; Double-Girder Nested Trolleys; Duct-o-Bar™ Connections; Box Track;		Switches; Curved Track; other components for complete monorail systems	Three Alu-Track series to choose from

## Why Spanco?

- 1 We manufacture the widest selection of pre-engineered, ready-to-ship workstation bridge cranes in America.
- 2 We are always willing and able to custom engineer crane solutions for your unique applications. Our business model readily handles *one-of-a-kind* design challenges.
- 3 Our engineers do comprehensive finite element analysis and destructive testing when required.
- 4 All of our enclosed track bridge cranes and monorails — including custom engineered models — meet or exceed standards set by:
  - The Occupational Safety and Health Administration (OSHA)
  - ANSI B30.11 standards for monorails and underhung cranes
  - Monorail Manufacturer's Association (MMA) MH27.2 standard for enclosed track underhung cranes and monorails systems – specifications
- 5 We deliver exceptional weld quality. In 2011, we earned AWS's prestigious Certified Welding Fabricator (CWF) designation for our comprehensive quality management systems that oversee our welding fabrication.
 
- 6 Our laser precision manufacturing assures you that your bridge crane will operate smoothly for years to come.
- 7 We've embraced ISO 9001:2008 systems as a means to monitor the quality of our interactions with customers, dealers, and reps.
- 8 All system proposals begin with an on-site evaluation of your material handling needs and expert recommendations by our trained Spanco dealers.
- 9 We engineer and manufacture a full portfolio of workstation lifting solutions — from jib cranes to gantry cranes — so you can be assured that all of our system recommendations will be guided by your application's best interests.
- 10 Our bridge cranes are delivered on-time and in the most protective packaging in the crane industry.
- 11 Our dealers give you on-going, on-site technical support.
- 12 Our bridge cranes are backed by the best warranties in the industry: 10-year on crane components, 1-year on electrical and motor systems.
- 13 All standard Spanco systems are designed to comply with IBC and Seismic Zone 4 strength requirements.



A 4000-pound capacity Spanco Freestanding Bridge Crane carefully lifts and moves an expensive machined part.



A custom-engineered 2000-pound capacity Spanco Freestanding Bridge Crane for a glass manufacturer.

# Bridge Crane Table of Contents

**2 Spanco Bridge Crane  
Selector Guide**

**3 Why Spanco?**

**6 Why Use Workstation  
Bridge Cranes?**

**8 Spanco  
Enclosed Tracks**  
For smooth, rigid, self-cleaning  
designs that are three times easier  
to operate.

**10 Freestanding  
Bridge Cranes**  
Install almost anywhere.

**12 Ceiling-Mounted  
Bridge Cranes**  
Build on what you already have.

**14 Alu-Track® Bridge  
Crane Systems**  
When lightweight and corrosion  
resistance are top priorities.

**18 Monorails**  
Lifting and travel for a  
fixed path.

**20 Bridge Cranes  
Components**  
Illustrated guide to standard  
components.

**22 Support Systems**  
Freestanding and Ceiling-Mounted  
support options for your  
Bridge Crane.

**24 System Options**  
Expand, customize, and power your  
lifting capabilities.

**27 Warranties & Warnings**  
Our warranties are the best  
in the business.



# Workstation Bridge Cranes

## Why Use Workstation Bridge Cranes?

### Add Overhead Crane Efficiency To Your Entire Production Line

Do your workers need to move heavy or large items from workstation to workstation? Are forklifts or other conveyances proving to be too awkward, slow, or hazardous for these tasks?

With a Spanco® Workstation Bridge Crane, loads from 250 to 4000 pounds can be easily moved by your employees.

Our bridge cranes' rectangular-shaped coverage areas can handle a cluster of workstations, or your entire production line, even your entire building. Our bridge crane runways are designed with cantilevers on both ends to extend beyond the center of your last column or hanger and allow you to easily add on to your current system.

- Eliminate manual lifting, empowering a single worker to move loads
- Supplement or replace multiple jib cranes and/or forklifts
- Provide smooth, lightweight, ergonomic movement

### Design Factors

- Nameplate bridge capacity represents the rated load on the hoist hook. The load rating of a hoist shall not exceed the bridge rating.

Spanco's design includes an allowance of 15% of nameplate capacity for dead weight of the trolley and hoist. An additional allowance of 25% of nameplate capacity is also included for impact.

### Service Factors

All Spanco workstation cranes are designed for frequent usage as defined:

- System or equipment is used where operational time is up to 100% of the work period, and lifted load is at 50% or below rated capacity.
- System or equipment is used where operational time is less than 50% of work period, and lifted load is greater than 50% of rated capacity.
- Applications involving vacuums, magnets, or other high impact lifters are considered severe usage (continuous service) and require special design considerations. Please contact Spanco.
- Consult factory for usage other than moderate and all instances of high cycle rates or high impact applications.

A prominent coupling corporation was searching for a material handling solution that would offer extensive plant coverage and flexibility.

After some investigation, the facility installed several Spanco Freestanding Workstation Bridge Cranes to provide more control over their manufacturing process. Now, an individual worker can manipulate heavy loads from one work area to another with precision and accuracy. These 4000-pound capacity bridge cranes are interconnected to create one fluid system that provides precise movement and unlimited coverage.

*Coupling manufacturer  
application of a Spanco  
Freestanding Bridge Crane*



### This Northeast John Deere dealership

replaced a jib crane and forklifts with a Spanco Ceiling-Mounted Workstation Bridge Crane that now covers their entire service area. Workers can quickly and easily move 800 pounds of tires and large implements to anywhere in the crowded shop. Machinery needing service can be lined up in rows for optimum use of scarce floor space. The new bridge crane itself required no new foundations and no floor space.

*John Deere dealer application  
of a Spanco Ceiling-Mounted  
Bridge Crane*

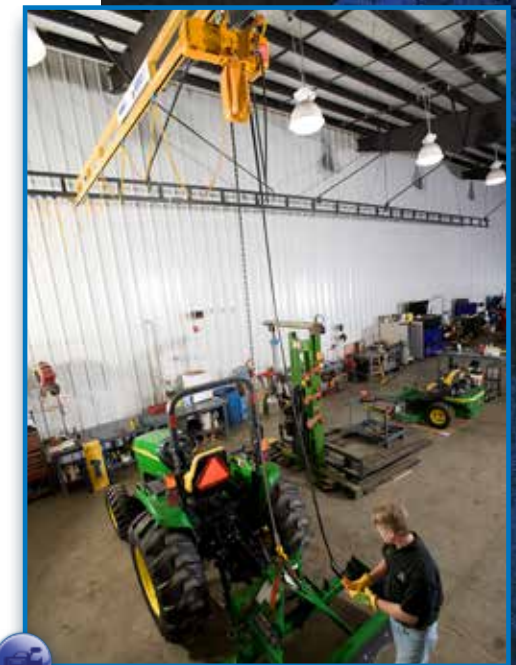

A leading OEM of agricultural equipment needed a way for single workers to move very long farm implements around their facility. Since the pieces followed a long but repetitive route, a Spanco® Monorail was specified. Not only is the monorail quiet and easy-to-use, but it also quickly navigates between columns and other obstacles that would stymie a loading being carried by a forklift.

*New Holland application  
of a Spanco Monorail System*



*An example of the enormous coverage area possible with Spanco Bridge Cranes. In this case, one freestanding system provides overhead lifting for virtually every workstation in the shop.*

**SPANCO** 2000 LBS. CAP.

*Nameplate Capacity*

## High Performance Enclosed Track

### Three Times Easier to Operate

At the heart of our bridge cranes are our smooth-running trolleys and enclosed track — making Spanco® systems three times easier to operate and control than patented track systems.

For example, an operator moving a 1000-pound load only needs about 10 pounds of force to begin its movement, and 8 pounds to continue its travel. With a 100 to 1 ratio, virtually any of your employees can move heavy materials with ease.

Not only is manual operation easy, it can be much faster than motorized cranes. (But if you're regularly moving 1000-pound loads, or if you can't easily walk next to your load due to workplace obstacles, a Spanco TrackBoss™ Tractor Drive offers power travel for your trolley. See page 24.)

### The Spanco V-shaped profile

prevents dust, debris, and ice from accumulating on the track. The self-cleaning V-shape also maintains wheel alignment for end trucks and trolleys, so they always glide effortlessly, day after day. Plus, the enclosed track continuously protects wheels from harm.

*End view of the profile of a trussed track. This 250-pound capacity Spanco Ceiling-Mounted Bridge Crane is used with a vacuum lifter at a flour packaging plant.*

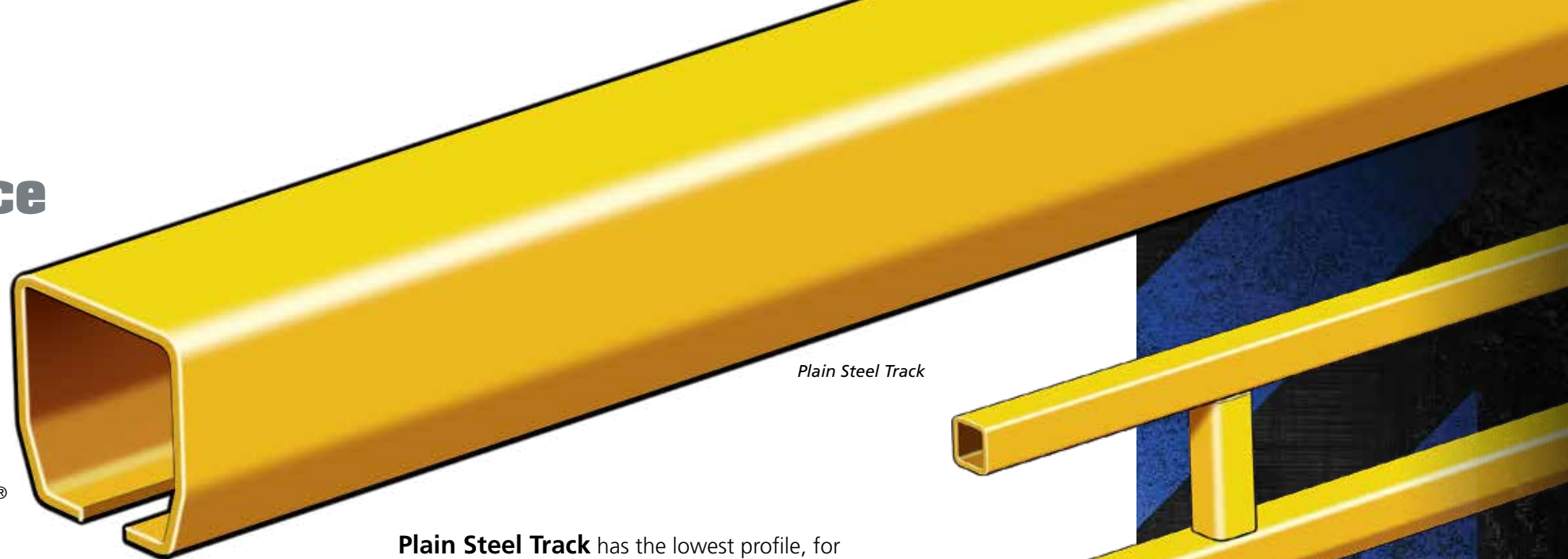

Plain Steel Track



Trussed Steel Track

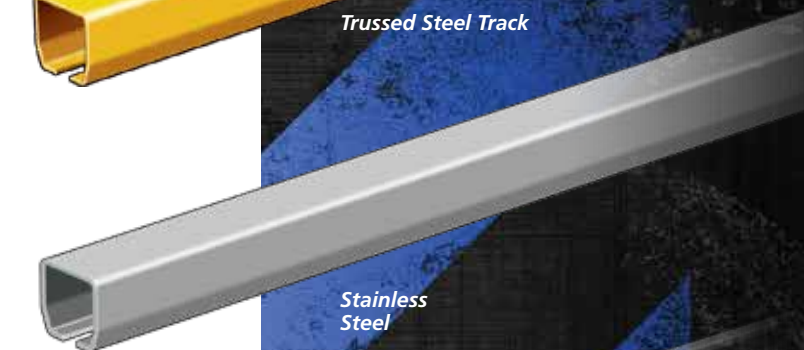

Stainless Steel



Alu-Track



Single Track Splice

Trussed Track Splice

**Plain Steel Track** has the lowest profile, for use with short spans.

**Trussed Steel Track** spans greater distances between supports. And the combination of high-strength to low-weight ratio reduces stress on the support structure.

### Track Options

- Alu-Track® high performance runways and bridges: see page 14
- Steel Track: rolled from ASTM A572, A607, or A715 grade steel; available with enamel, powder, epoxy, or galvanized coatings
- Stainless Steel Track: 304 stainless for 500 Series track
- Mylar™ Lip Seal: for additional track protection from very heavy dust or paint overspray applications

### Easily install, expand, or relocate

your bridge crane at any time. By simply adding runway sections and additional bridges, your system grows and adapts to your changing production situation. Splice Joints connect the track sections and come with vertical and horizontal adjustment screws for precise alignment of the track sections. Trussed Splice Joints join the top chord of the truss, connecting track sections in precise alignment.

*End profile of track with trolley wheel; design provides self-centering and self-cleaning*

# Freestanding Bridge Cranes

## Install Almost Anywhere

**Spanco® Freestanding Workstation Bridge Cranes** provide highly effective, cost efficient lifting and moving solutions, especially when:

- You need flexibility: these bolt-together freestanding systems can be readily relocated, either within your plant or in an entirely new location.
- Your roof support is inadequate for a Spanco Ceiling-Mounted Bridge Crane. Typically, a standard 6 inch thick reinforced concrete floor is all that's needed for our freestanding bridge cranes.
- You do not want a system that must attach to your building's support columns.
- You need the flexibility to readily add runway lengths and bridges — or extend your coverage to multiple work areas — at any time



*This police garage can do major maintenance tasks much easier now with a 2000-pound capacity Spanco Freestanding Bridge Crane.*

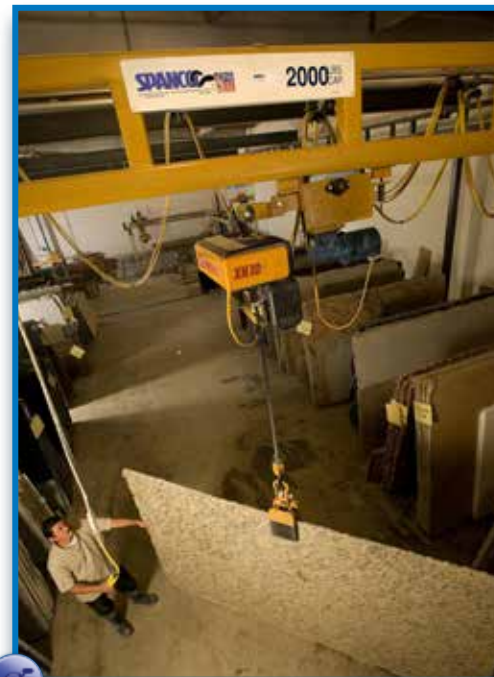

*Storage and retrieval of granite countertops is a one-man task using this 2000-pound capacity Spanco Freestanding Bridge Crane.*

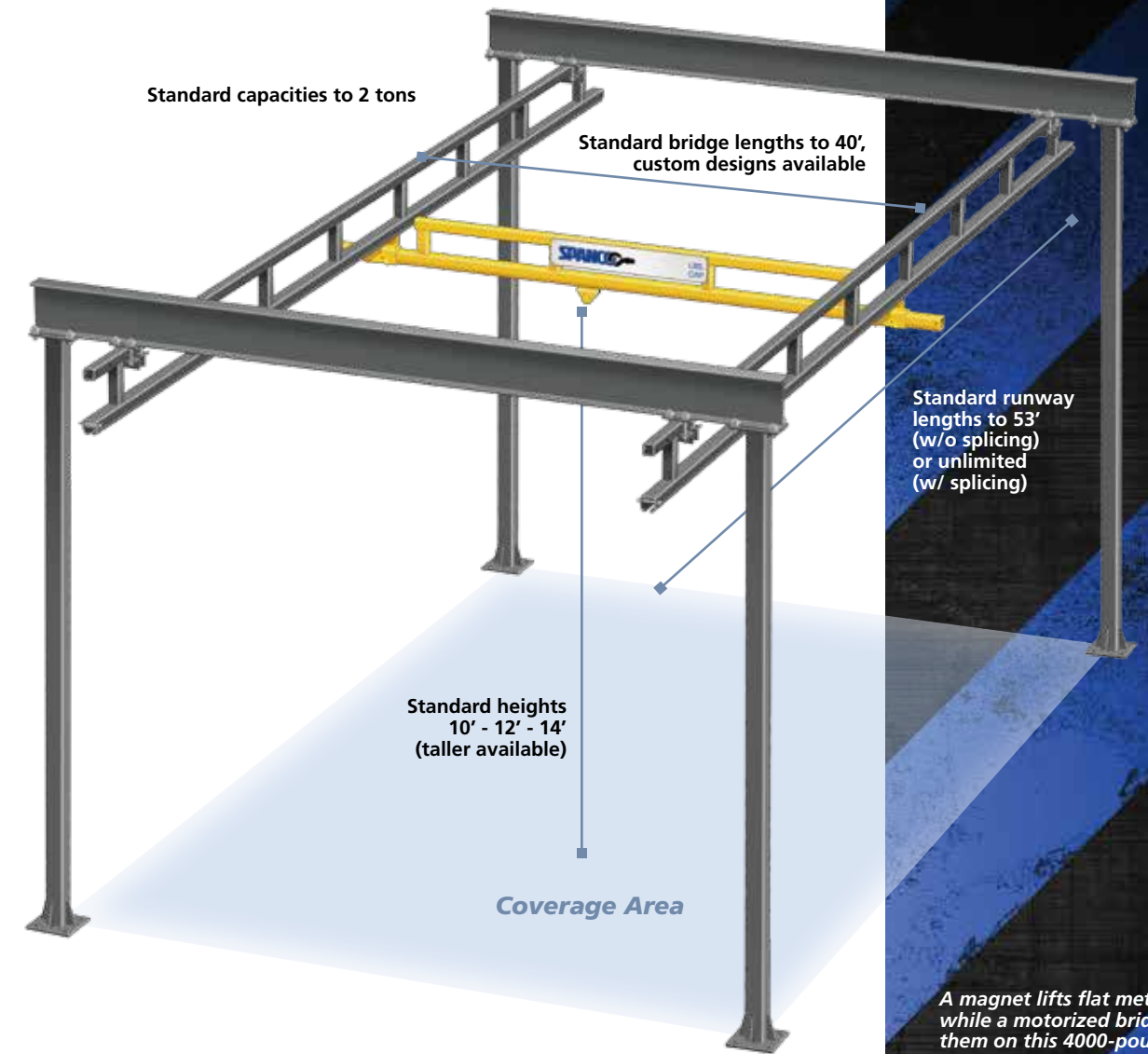

*A magnet lifts flat metal plates, while a motorized bridge moves them on this 4000-pound Spanco Freestanding Bridge Crane.*

### Spanco Freestanding Bridge Cranes

**Capacities:** 250 to 4000 lbs.

**Bridge Lengths:** Standard up to 34' (Overall) available to 40'

**Runway Support Centers:** Standard up to 40'

**Runway Lengths:** 53' (w/o splicing) or unlimited (w/ splicing)

**Height:** 10', 12', or 14' heights (Floor-to-Trolley Clevis) standard (taller available)

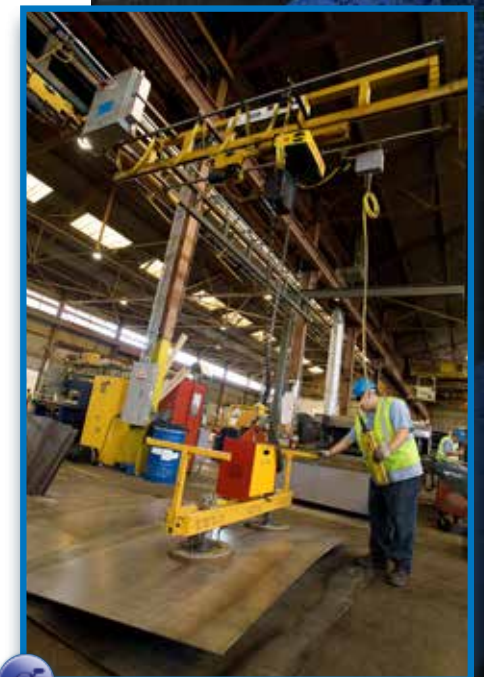

# Ceiling-Mounted Bridge Cranes

## Build on What You Already Have

**Spanco® Ceiling-Mounted Bridge Cranes** make the most of your existing building and production floor space. By mounting the crane to your existing building structure, you'll save the cost of support columns and headers — while eliminating any interference they might have caused.

- Hangs from existing roof beams or trusses.
- Requires no system support columns and no attachments to building columns.
- Takes up no production floor space, so forklifts or other machinery can easily pass underneath the system.
- Allows you to readily add runway lengths and bridges — as well as links to monorail crane systems — at any time.



*A refrigerator manufacturer using a 250-pound capacity Spanco Ceiling-Mounted Bridge Crane.*

*Spanco Ceiling-Mounted Bridge Cranes have numerous mounting configurations to adapt to a variety of roof support structures. See page 22 for more information.*

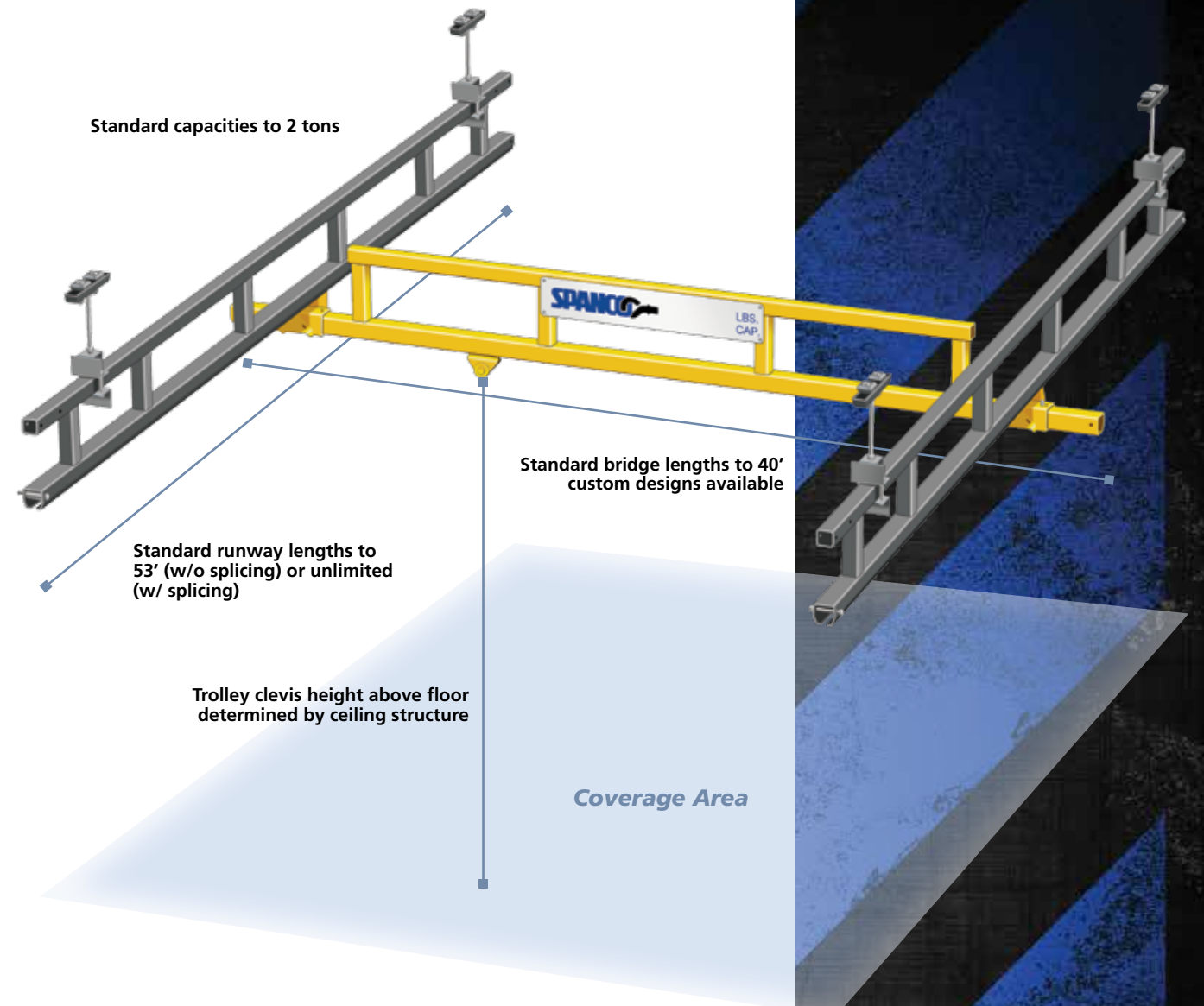

### Spanco® Ceiling-Mounted Bridge Cranes

**Capacities:** 250 to 4000 lbs.

**Bridge Lengths:** Standard up to 34'  
(Overall) available to 40'

**Runway Support Centers:** Up to 40'

**Runway Lengths:** 53' (w/o splicing) or  
unlimited (w/ splicing)

**Height:** Determined by ceiling structure &  
(Floor-to-Trolley Clevis) application; we recommend as  
low as practical to minimize  
trolley resistance.

*Like all Spanco Bridge Cranes, this ceiling-mounted system is compatible with numerous hoists, manipulators, and balancers. In this plant, a vacuum lifter is used to palletize large sacks of flour.*



# Alu-Track Bridge Cranes and Runways

## Our Most Agile Cranes

**For super-responsive crane performance**, we make Spanco® Alu-Track® Bridge Cranes and Runways from our lightweight aluminum enclosed track.

Not only are these bridges easier to move, but Alu-Track bridges and/or runways mean less weight on your roof support structure for ceiling-mounted systems, expanding their applicability.

In addition, Alu-Track bridges and runways are spark resistant, highly durable, non-corroding, and maintenance-free, making them suitable for:

- Clean rooms
- Refrigerated areas, including food packaging applications
- Moisture-laden environments
- Acidic environments (but not for base/alkaline)
- R&D labs
- Wherever highly agile cranes are required



*A female worker uses a 1000-pound capacity Spanco Alu-Track Bridge Crane to position product in her work area.*

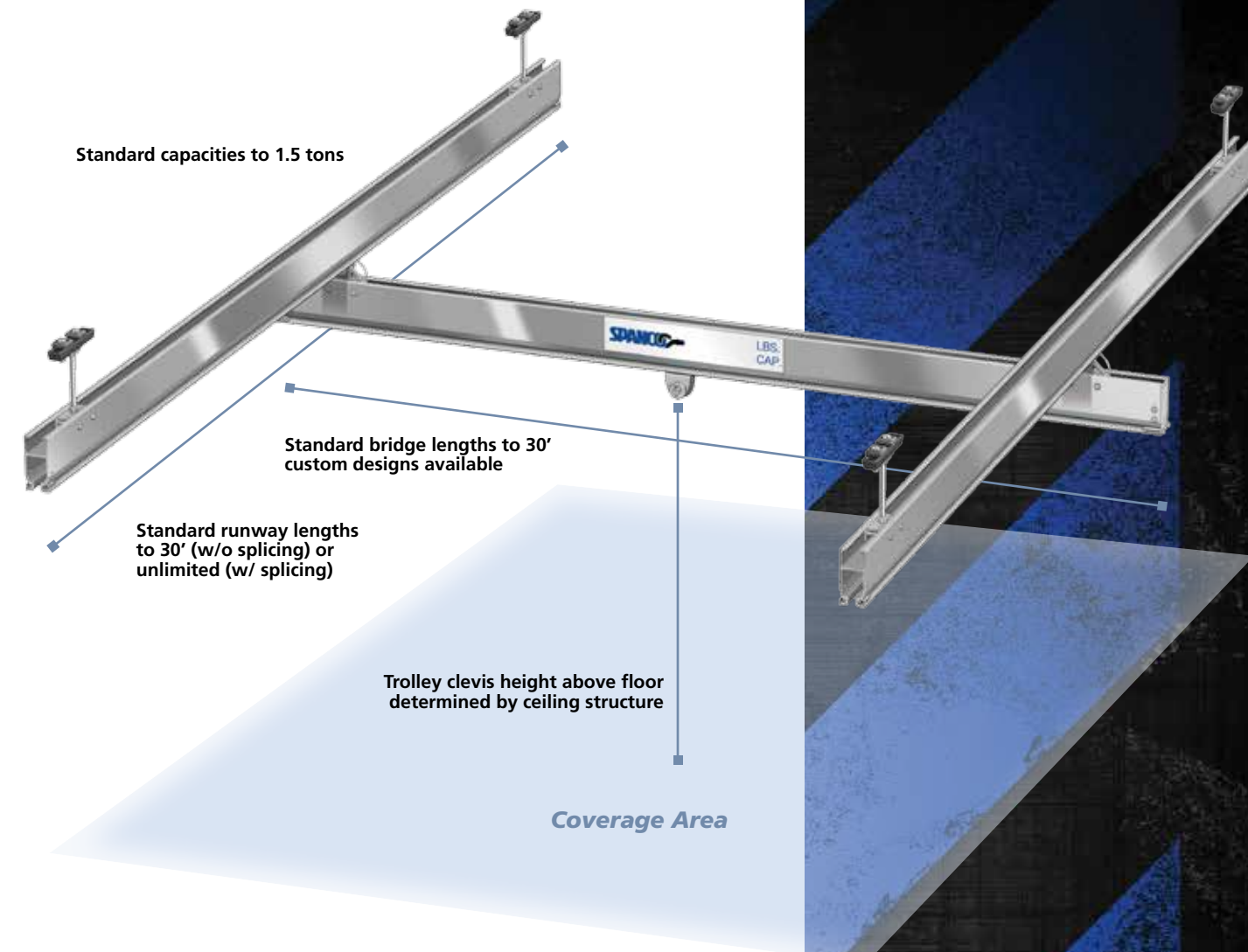

### Spanco Alu-Track Bridge Cranes

**Track Applications:** Workstation bridge cranes & runways (including monorails)

**Material:** Extruded, high-strength, 6061-T6 aluminum alloy

**Capacities:** 250 to 3000 lbs.

**Bridge Lengths:** Up to 30'

**Runway Support Centers:** Up to 29', dependant on load capacity

**Runway Lengths:** 30' (w/o splicing) or unlimited (w/ splicing)

**Height:** Determined by ceiling structure & application; we recommend as low as practical to minimize trolley resistance.

*Alu-Track system with both runway and bridge of aluminum.*





# Alu-Track Bridge Cranes and Runways

## Track Profiles and Series

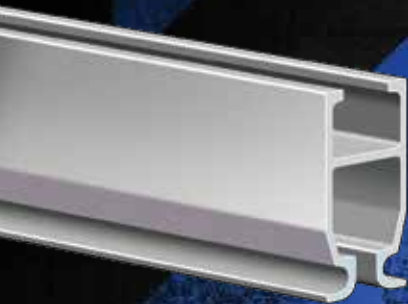

306 Alu-Track



308 Alu-Track



308 Reinforced  
Alu-Track

**306 Alu-Track:** 6 inch overall height, with same internal dimensions as the Spanco® 600 Series steel enclosed track.

**308 Alu-Track:** 8 inch overall height, with same internal dimensions as the Spanco 700 Series steel enclosed track.

**Reinforced 308 Alu-Track:** 12.5 inch overall height, with same internal dimensions as the Spanco 700 Series steel enclosed track, plus an extruded, reinforcing strong-back for heavier loads over longer spans.

### Alu-Track® Configurations

Alu-Track internal profiles are identical to Spanco 600 and 700 steel series tracks allowing interchangeable use of aluminum bridges on steel runways.

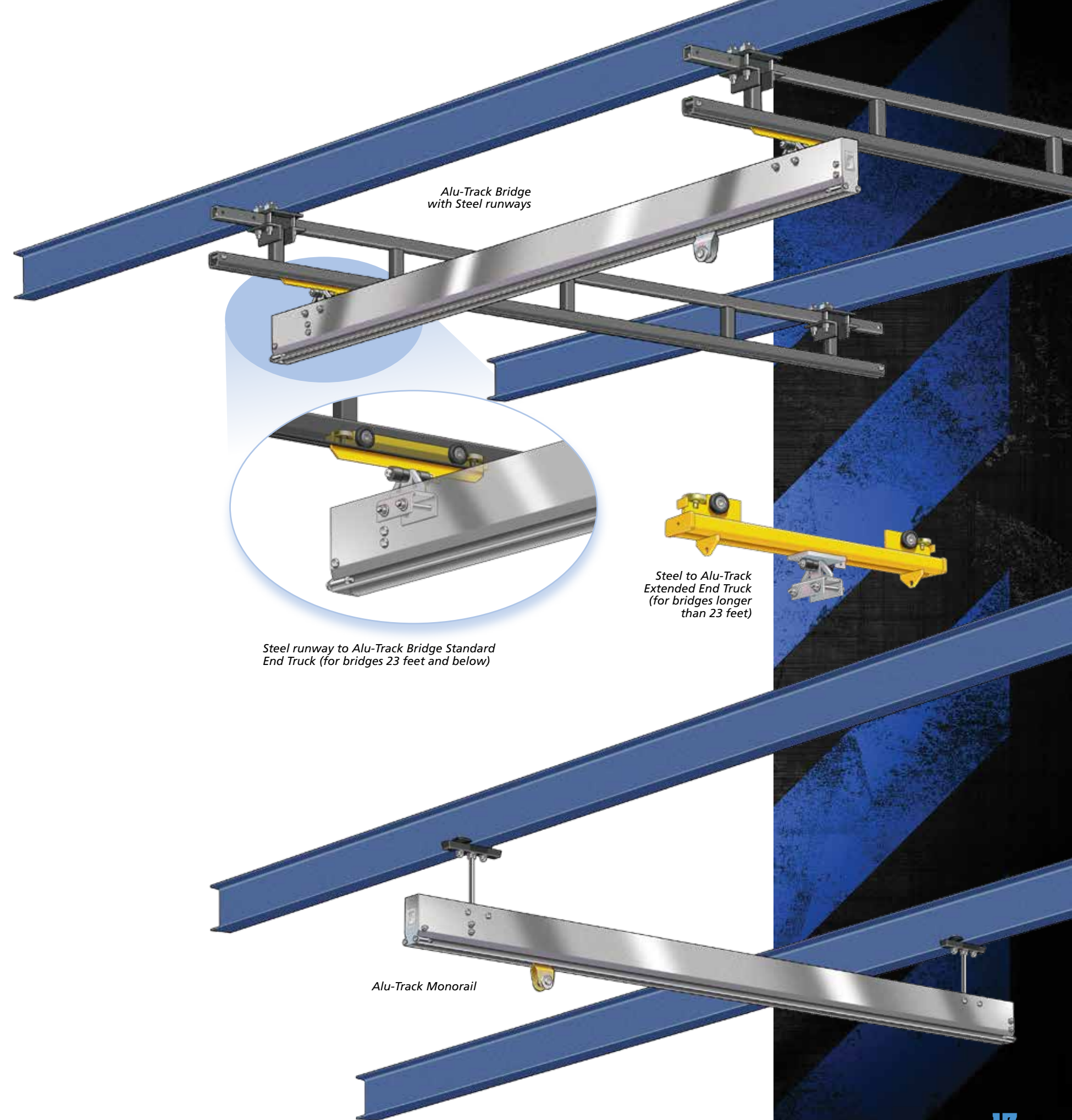

Alu-Track Bridge  
with Steel runways

Steel runway to Alu-Track Bridge Standard  
End Truck (for bridges 23 feet and below)

Steel to Alu-Track  
Extended End Truck  
(for bridges longer  
than 23 feet)

Alu-Track Monorail

## Ceiling-Mounted Monorails

### Straight to the Point

**Spanco® Monorails** are ideal for production processes that require lifting and moving products along a fixed path, such as machining centers, moving raw materials to workstations, or warehouse-to-warehouse transfer.

These economical monorails are also an excellent alternative for work areas that cannot be serviced by bridge cranes, such as hard-to-reach locations or buildings with high ceilings.

Our monorails have great layout flexibility, including curves, multiple tracks, switches to multiple spurs, turntables, interlocks, and entry/exit sections. And, they can readily connect to other monorail systems to extend coverage to multiple work areas or your entire facility.

#### Ceiling-Mounted Monorails - Straightforward Installation, With Layout Flexibility

Our ceiling-mounted monorails use no floor space or support columns. The monorail tracks can be:

- Flush-mounted parallel to ceiling beams, or
- Cross-mounted to ceiling beams, or
- Mounted with any length drop-rods (requires sway bracing), including hangers for slopes up to 14 degrees
- Available with switches, curved track, and other components needed for a complete monorail system

**Our Freestanding Monorail Cranes** are perfect for a variety of different buildings and facilities. Floor mounted monorails offer more custom features than our other models. Floor mounted monorails are perfect when:

- Building structure cannot support a crane
- Ceilings have other obstructions (air ducts, skylights, overhead storage)
- You need a semi-permanent solution due to rental agreements
- You want a customized width and length
- You want to use a floor mounted monorail in conjunction with a ceiling mounted system.

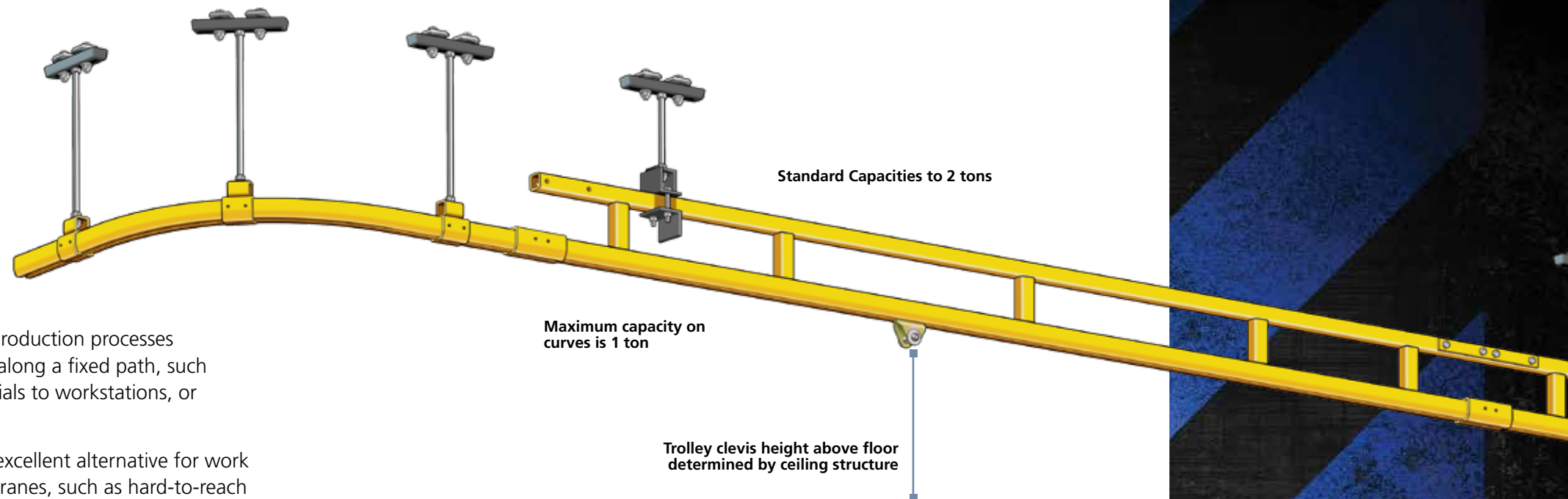

#### Spanco Ceiling-Mounted Monorails

**Capacities:** 250 to 4000 lbs.

**Runway Lengths:** Up to 53' (w/o splices)

**Trussed Tracks:** Steel, stainless steel, or Alu-Track®  
(Enclosed tracks)

**Height:** Determined by ceiling structure & application; we recommend as low as practical to minimize trolley resistance.  
(Floor-to-Trolley Clevis)



*An agricultural equipment manufacturer using a 2000-pound Spanco Ceiling-Mounted Monorail to move finished product.*

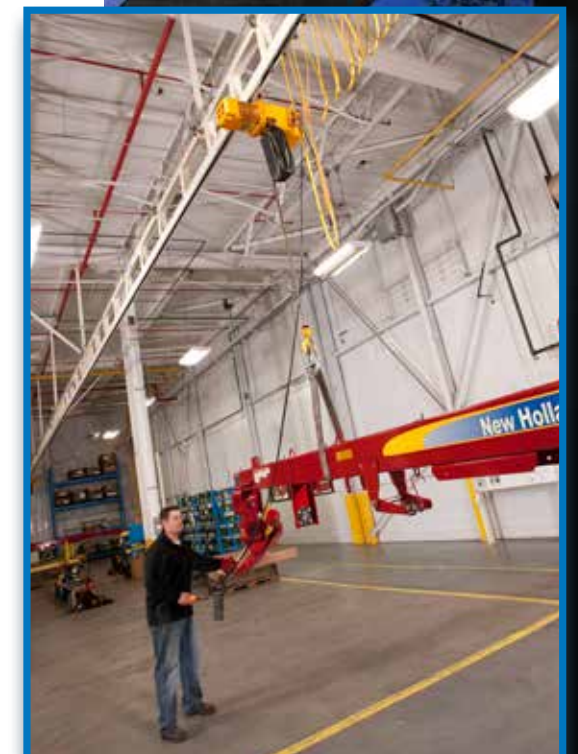

# Superior Component Engineering

- 1 End Stop Bumpers** with resilient rubber casings for increased impact resistance. Bumpers are through-bolted to the enclosed track and are provided with all systems.
- 2 Festoon Sections** are through-bolted onto an end of a runway to allow stack-up of cable/hose trolleys. Festoon trolleys pass under the through-bolt and into the festoon section.
- 3 Cable/Hose Clamps** attach to one end of the runway (the festooning section) and one end of the bridge. Standard clamp accommodates flat cable, 4 wire, #14 AWG. Optional clamps hold 3/8 inch air hose.
- 4 Cable/Hose Trolleys** convey flat electrical cable or round air hose. Four wheels insure easy rolling. Pivoting clevis provides swiveling action for air hose. Maximum air hose capacity for standard trolleys is 1/2 inch; special trolleys available for larger festooning.
- 5 Flat Cable Festooning Systems** (4 wire, #14 AWG) are supplied with all bridge crane systems. Festoon loops are 18 inches for bridges and 36 inches for runways. Optional air hose festoons available for various sizes of hose.
- 6 End Trucks** carry the bridge crane along the runways. Horizontal steel guide rollers on either end of the end truck guards against *crabbing* of workstation bridge crane.\*
- 7 Hoist Trolleys** are fabricated from precision-cut steel plate.\*

\*End Trucks and Hoist Trolleys both have quiet, long-lasting, large diameter, polyamide wheels equipped with anti-friction ball bearings. Other options available include steel wheels, zinc chromate-plated finish, or bronze wheels with bronze guide rollers for spark proof applications.



## Hanger Assemblies:

- A** For **Spanco Ceiling-Mounted Systems**, threaded rod hangers are standard, with flush-mount hangers available; see page 22 for more information.
- B** For **Spanco Freestanding Systems** (as shown here), provided flush type hangers allow for adjustment in lateral and longitudinal directions.

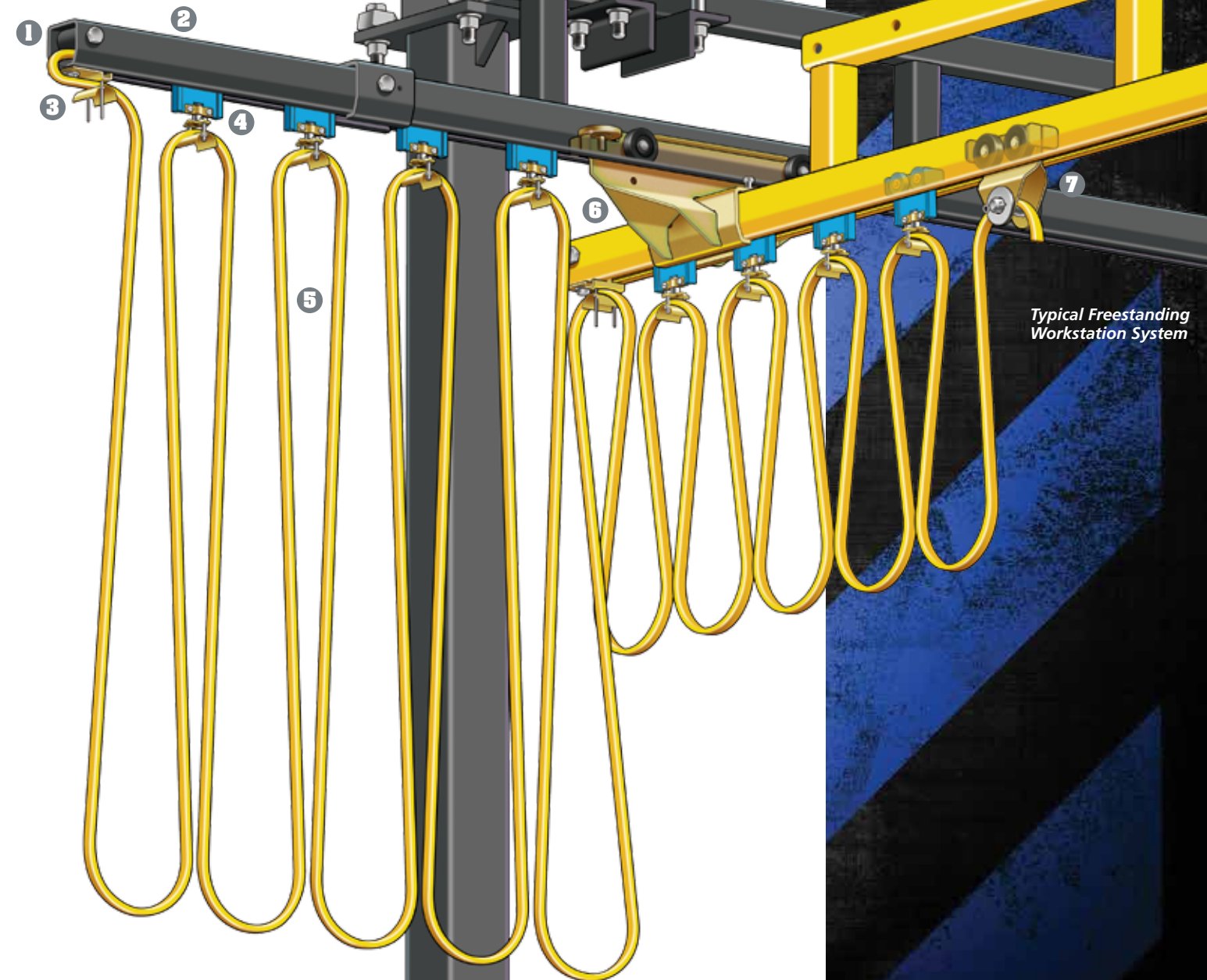

Typical Freestanding Workstation System



# Workstation Bridge Crane Support Systems

Freestanding System

## Freestanding

**Freestanding systems** are easily installed with the aid of a forklift. Welded steel base plates with gussets provide solid mounting connections between our steel support columns and your concrete floor. All support columns are designed to AISC specifications. All Spanco® systems are designed to comply with IBC and Seismic Zone 4 requirements.

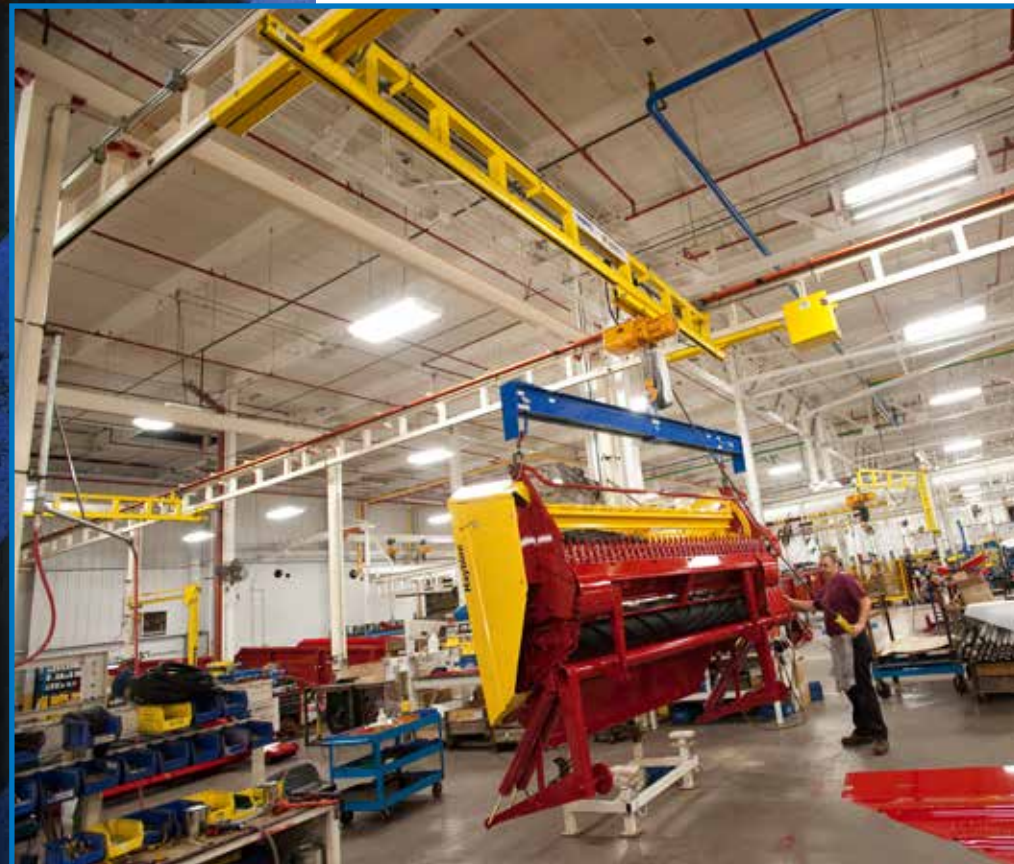

An agricultural equipment manufacturing operation using a freestanding workstation bridge crane with runways supported by steel columns.

## Ceiling-Mounted

### Standard Threaded Rod Hangers

Spanco Standard Threaded Rod Hanger assemblies are provided with all Ceiling-Mounted Bridge Cranes and Monorail Systems:

- Adjustable roof beam clamp for secure fit to horizontal beams. Accommodates flange widths from 2¼ inches to 8 inches and flange thicknesses up to 7/16 inch. Upon request, alternative clamps can be provided for larger beams or for beams sloped up to 14 degrees.
- Standard 12 inch threaded rod provided, with longer rods available. Threaded rods can be custom cut on-site as needed.
- Requires sway bracing (see below).
- All threaded rods are made from Grade B7 material

### Sway Bracing for Standard Hangers

- Sway bracing is required on all threaded rod supported systems to ensure maximum runway rigidity and, in turn, optimum end truck performance.
- Our optional sway brace bracket attaches to our standard rod and track clamp. The bracket then holds 1 inch diameter, schedule 40 pipe at a 45 degree angle. The 1 inch pipe is not supplied by Spanco.

### Flush Clamps for Mounting of Runways

- Optional hanger assembly for attaching plain track runway to support steel. Fabricated from structural plate and equipped with two Grade 5 bolts and beam clips.
- Accommodates flange widths from 2¼ inches to 8 inches and flange thicknesses up to 7/16 inch. Larger flange widths and thicknesses available.
- Note: check that your bridge's intended use will leave sufficient overhead clearance. For example, equipment or hoses rising above the bridge may not clear your support beam.

Flush Clamp for Cross Mounting plain track runways.

Flush Clamp for Parallel Mounting plain track runways. Compatible with plain, trussed, and Alu-Track® bridges.

Trussed Track Drop Hanger

Sloped hangers with drop rods

Sway Bracing

Flush Clamp -Cross Mount

Flush Clamp -Parallel Mount

# Workstation Bridge Crane System Options

**Mixed Capacity Systems** leverage system capability by specifying heavier capacity runways that can accept multiple smaller capacity crane bridges. For example: a 2000-pound capacity runway can run two 1000-pound capacity crane bridges, or four 500-pound capacity crane bridges.



Mixed Capacity System



Bridge Buffer

**Bridge Buffers** roll in the runway tracks between two crane bridges, keeping the bridges apart so as not to overload the runway's capacity.

**TrackBoss™ Tractor Drives** motorize the travel of your hoist trolley or bridge crane. Typically specified when loads regularly exceed 1000-pounds. These drives are also extremely helpful when transporting material into hard-to-reach areas where operator movement is difficult due to machinery, work tables, or other obstacles.

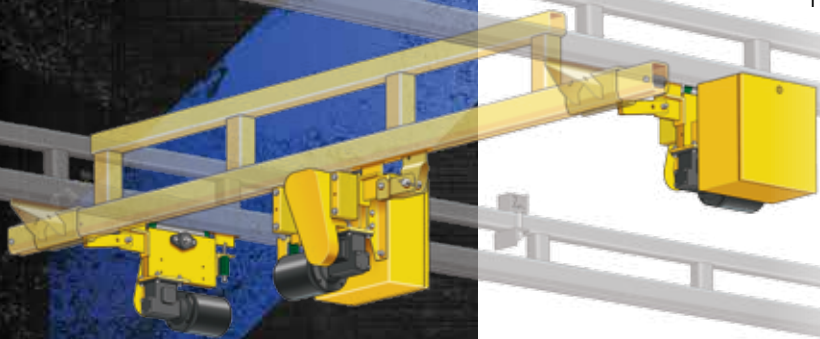

Tractor Drives mounted on bridge and runways



Track Boss Tractor Drive

**Intermediate Stops** ("Bumpers") are through-bolted at runway support centers to prevent more than one bridge crane from operating within a set of support centers. **NOT TO BE USED AS END STOPS.**



Intermediate Stop

Intermediate Stop placed inside a runway

**Double-Girder Nested Trolleys**, also known as High Hat or Crab Trolleys, increase the available lift height in low headroom applications. The hoist is nested between dual girders that form a box-shaped assembly that rises above a set of parallel, connected bridges.



Double Girder End Trucks

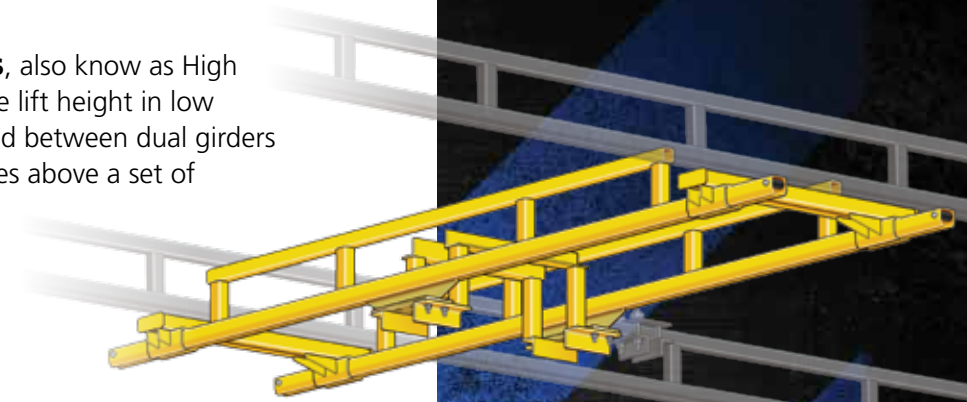

Double-Girder Nested Trolley

**Box Tracks** allow festooning cables/hoses to run in their own box track, typically positioned out-of-the-way, above the runway or bridge.

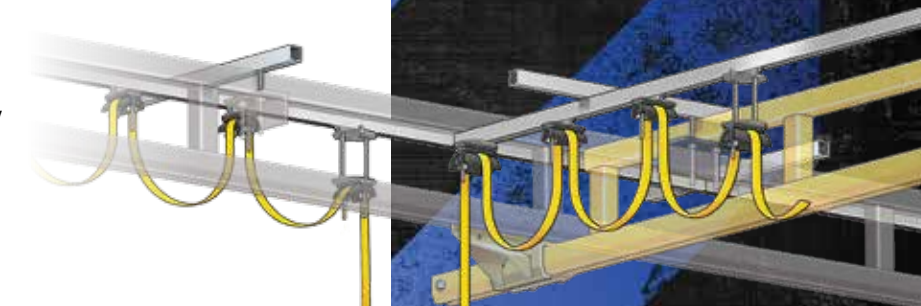

Box Tracks

**Duct-O-Bar™ \* Electrical Connections** use a solid electrical bar and brushes in conduit as an alternative to festooning cable. The connections run adjacent to the enclosed track on runways or bridges.

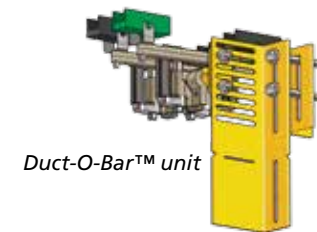

Duct-O-Bar™ unit

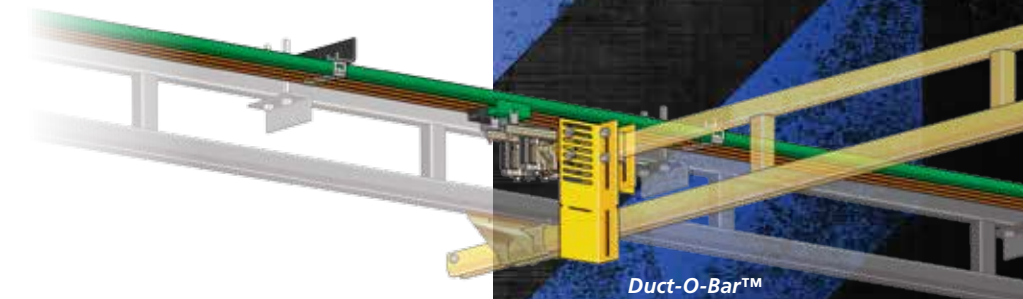

Duct-O-Bar™ installation

**Vacuum Hose Trolleys** provide effortless movement of vacuum hoses. Features anti-kick-up rollers and Velcro straps to festoon vacuum hose for vacuum lifters.



Vacuum Hose Trolley

Steel Wheels

**Steel Wheels** for trolleys and end trucks are also available with zinc dichromate-plated finish or stainless.

**Bronze Wheels** for trolleys and end trucks feature bronze guide rollers for *spark proof* applications.



Bronze Wheels

\*Duct-O-Bar is a trademark of the Duct-O-Wire Company.

## Workstation Bridge Crane System Options



Telescoping Bridge reaches under doorways and around columns

## Extended Crane Coverage

For bridge cranes that extend beyond your runways, we can engineer systems using the following three designs:

**Telescoping Bridges:** provide extended crane reach, allowing you to easily place parts into machinery or into a neighboring workstation or bridge crane system. The telescoping bridge cranes also let you to reach beyond a support column, as well as underneath a mezzanine.

Anti-kick-up wheels keep the telescoping bridge's movement smooth, even when carrying up to 2000 pounds. Spanco® Telescoping Bridges also exclusively use steel wheels that provide the user with an easy-glide lifting experience. To watch our telescoping bridge in action, visit [Spanco.com](http://Spanco.com).

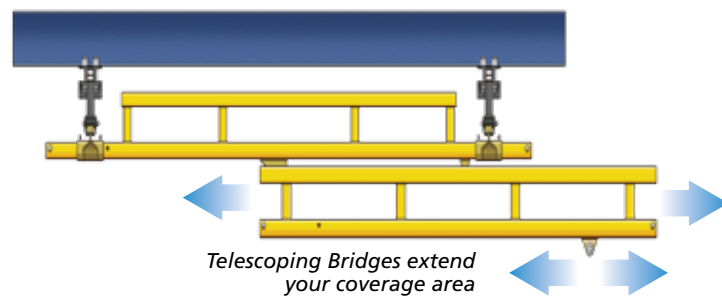

## Bridge-Mounted Articulating Jib Crane

An articulating jib crane can be mounted to a workstation bridge to provide extended reach beyond runways and to move loads around obstacles or into machinery. Spanco Bridge-Mounted Articulating Jib Cranes also provide 360-degree rotation and extensive headroom and clearance—both below and above the boom. These articulating jibs can support nearly any type of manipulator, balancer, or hoist.



Bridge-Mounted Articulating Jib Crane

## Best Warranty in the Industry

## Workstation Bridge Cranes Warranties & Warnings

### The 10-Year Spanco Warranty

#### Products covered under the 10-Year Warranty:

- Manual Steel Freestanding, Ceiling Mounted Workstation Bridge Cranes, and Monorails
- Manual Aluminum (Alu-Track®) Workstation Bridge Cranes and Monorails
- Manual Jib Cranes (I-Beam, Articulating, and Workstation Jib Cranes)

#### What the 10-Year Warranty covers:

- Defects in Equipment material and workmanship
- Wearable parts (end truck and trolley wheels only)

**Spanco, Inc.** ("Spanco") warrants the Equipment and wearable end truck and trolley wheels only, to be free from defects in material and workmanship for a period of ten (10) years or 20,000 hours (whichever occurs first), commencing on the date of shipment to the first retail purchaser ("Purchaser"). This Warranty does not extend to Equipment which has been subject to misuse, use in excess of rated capacity, negligent operation, use beyond Spanco's published service factors, improper installation or maintenance, and does not apply to any Equipment which has been repaired or altered without Spanco's written authorization. Written notice of any claimed defect must be given to Spanco within thirty (30) days after such defect is discovered. Spanco's obligation, and Purchaser's sole remedy under this Warranty is limited to, at Spanco's discretion, the replacement or repair of the Equipment at Spanco's factory or at a location approved by Spanco. Purchaser is responsible for all freight and transportation costs relating to the repair or replacement of the Equipment. THE FOREGOING WARRANTY IS EXPRESSLY IN LIEU OF ALL OTHER WARRANTIES WHATSOEVER WHETHER EXPRESS, IMPLIED, OR STATUTORY. SELLER MAKES NO WARRANTY AS TO THE MERCHANTABILITY OR FITNESS FOR A PARTICULAR PURPOSE OF THE EQUIPMENT AND MAKES NO OTHER WARRANTY, EITHER EXPRESS OR IMPLIED. Spanco shall not be liable, under any circumstances, for any indirect, special or consequential damages including, but not limited to, lost profits, increased operating costs or loss of production. This Warranty shall not extend to any components or accessories not manufactured by Spanco (such as casters), and Purchaser's remedy for such components and accessories shall be determined by the terms and conditions of any warranty provided by the manufacturer of such components and accessories.

NOTE: All motorized Spanco products come with a 1-Year Warranty on drive components.

# Spanco family of Lifting Solutions



Ceiling-Mounted  
Workstation  
Bridge Cranes



Freestanding  
Workstation  
Bridge Cranes



Lightweight and Portable  
Aluminum Gentries



Versatile Steel  
Gantry Cranes



Wall-Mounted  
Jib Cranes

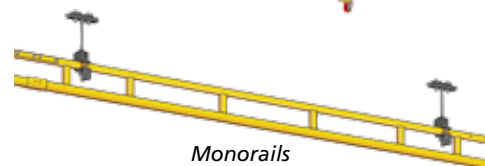

Monorails



Freestanding  
Jib Cranes

**To learn more** about Spanco's full line of material handling products, including Jib Cranes, Gantry Cranes, and Workstation Bridge Cranes, please visit **Spanco.com** from your desktop computer or mobile device.

## Workstation Bridge Cranes Next Step

Our engineering department stands ready to help you or your qualified architect or engineer address any and all challenging applications. If you ever have any questions regarding the installation, operation, or maintenance of your bridge crane, call us at 800-869-2080.

To find your manufacturer's rep, visit **Spanco.com** or call us at **800-869-2080**. We'll connect you with the most qualified local Spanco distributor for your application. Your distributor will gladly review your needs — firsthand and in-person — and make expert recommendations. We stand ready to delivery on our Promise To Perform.



604 Hemlock Road  
Morgantown, PA 19543 USA  
info@Spanco.com □ Spanco.com

USA/Canada: 1-800-869-2080  
Local Phone: 610-286-7200  
Mexico: 95-800-270-1080

©2014 Spanco®, Inc. All rights reserved. All specifications and product designs subject to change without notice. All trademarks are the sole property of their respective owners.

SP-WBC-BR0314V1